

TECHNICAL DATA

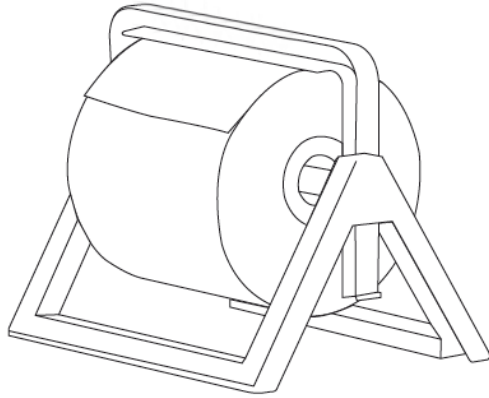

PHYSICAL PROPERTIES

HEIGHT	250 MM
WIDTH	440 MM
DEPTH	305 MM
NET WEIGHT	0.9 KG
MAIN MATERIAL	ABS
COLOR	WHITE

APPLICATION

COUNTER-TOP OR WALL MOUNTED DISPENSER FOR INDUSTRIAL ROLLS WITH A MAXIMUM DIAMETER OF 35 CM. EQUIPPED WITH A HACKSAW TO CUT THE PAPER QUICKLY AND ACCURATELY, AVOIDING WASTE OF PAPER.

PACKAGING

CARTON SIZE	267 x 444 x 312 MM
QTY/CTN	1 PCS/CTN
G.W.	1.5 KG/CTN

PRODUCT FEATURES

- + INDUSTRIAL ROLL HOLDER
- + METHOD OF FIXING: SCREWS AND WALL PLUGS (MOUNTING KIT INCLUDED)
- + MOUNTING HEIGHT: DESK- OR WALL MOUNTED
- + HIGH FILLING CAPACITY, SUITABLE FOR NORMAL TO HIGH-TRAFFIC AREAS

MAX. ROLL SIZE

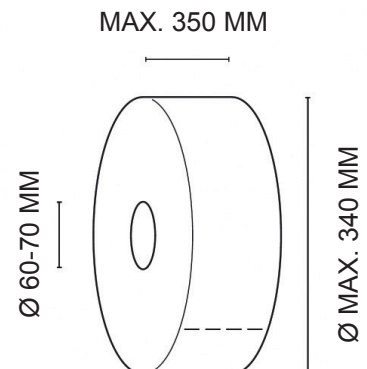

PRODUCT DESCRIPTION

REFILL CAPACITY	MAX. ROLL WIDTH: 340 MM MAX. ROLL DIAMETER: 350 MM
REFILL TYPE	INDUSTRIAL PAPER ROLL
CORE DIMENSIONS	60-70 MM

TECHNICAL DATA



ART. CODE: 1701673
GTIN: 4049657039021

CWS HYGIENE INTERNATIONAL GMBH
DREIEICH PLAZA 1A
63303 DREIEICH, GERMANY
WWW.CWS.COM / CONTACT@CWS.COM